

CHAPTER 29

WATER SUPPLY AND DISTRIBUTION

SECTION P2901 GENERAL

P2901.1 Potable water required. *Dwelling units* shall be supplied with potable water in the amounts and pressures specified in this chapter. In a building where a nonpotable water-distribution system is installed, the nonpotable system shall be identified by color marking, metal tags or other appropriate method. Where color is used for marking, purple shall be used to identify municipally reclaimed water, rain water and gray water distribution systems. Any nonpotable outlet that could inadvertently be used for drinking or domestic purposes shall be posted.

SECTION P2902 PROTECTION OF POTABLE WATER SUPPLY

P2902.1 General. A potable water supply system shall be designed and installed as to prevent contamination from nonpotable liquids, solids or gases being introduced into the potable water supply. Connections shall not be made to a potable water supply in a manner that could contaminate the water supply or provide a cross-connection between the supply and a source of contamination unless an *approved* backflow-prevention device is provided. Cross-connections between an individual water supply and a potable public water supply shall be prohibited.

P2902.2 Plumbing fixtures. The supply lines and fittings for every plumbing fixture shall be installed to prevent backflow. Plumbing fixture fittings shall provide backflow protection in accordance with ASME A112.18.1.

P2902.3 Backflow protection. A means of protection against backflow shall be provided in accordance with Sections P2902.3.1 through P2902.3.6. Backflow prevention applications shall conform to Table P2902.3, except as specifically stated in Sections P2902.4 through P2902.5.5.

P2902.3.1 Air gaps. Air gaps shall comply with ASME A112.1.2 and air gap fittings shall comply with ASME A112.1.3. The minimum air gap shall be measured vertically from the lowest end of a water supply outlet to the flood level rim of the fixture or receptor into which such potable water outlets discharge. The minimum required air gap shall be twice the diameter of the effective opening of the outlet, but in no case less than the values specified in Table P2902.3.1. An air gap is required at the discharge point of a relief valve or piping. Air gap devices shall be incorporated in dishwashing and clothes washing *appliances*.

P2902.3.2 Atmospheric-type vacuum breakers. Pipe-applied atmospheric-type vacuum breakers shall conform to ASSE 1001 or CSA B64.1.1. Hose-connection vacuum breakers shall conform to ASSE 1011, ASSE 1019, ASSE 1035, ASSE 1052, CSA B64.2, CSA B64.2.1, CSA

B64.2.1.1, CSA B64.2.2 or CSA B64.7. These devices shall operate under normal atmospheric pressure when the critical level is installed at the required height.

P2902.3.3 Backflow preventer with intermediate atmospheric vent. Backflow preventers with intermediate atmospheric vents shall conform to ASSE 1012 or CAN/CSA B64.3. These devices shall be permitted to be installed where subject to continuous pressure conditions. The relief opening shall discharge by air gap and shall be prevented from being submerged.

P2902.3.4 Pressure-type vacuum breakers. Pressure-type vacuum breakers shall conform to ASSE 1020 or CSA B64.1.2 and spillproof vacuum breakers shall comply with ASSE 1056. These devices are designed for installation under continuous pressure conditions when the critical level is installed at the required height. Pressure-type vacuum breakers shall not be installed in locations where spillage could cause damage to the structure.

P2902.3.5 Reduced pressure principle backflow preventers. Reduced pressure principle backflow preventers shall conform to ASSE 1013, AWWA C511, CSA B64.4 or CSA B64.4.1. Reduced pressure detector assembly backflow preventers shall conform to ASSE 1047. These devices shall be permitted to be installed where subject to continuous pressure conditions. The relief opening shall discharge by air gap and shall be prevented from being submerged.

P2902.3.6 Double check-valve assemblies. Double check-valve assemblies shall conform to ASSE 1015, CSA B64.5, CSA B64.5.1 or AWWA C510. Double-detector check-valve assemblies shall conform to ASSE 1048. These devices shall be capable of operating under continuous pressure conditions.

P2902.4 Protection of potable water outlets. Potable water openings and outlets shall be protected by an air gap, reduced pressure principle backflow preventer with atmospheric vent, atmospheric-type vacuum breaker, pressure-type vacuum breaker or hose connection backflow preventer.

P2902.4.1 Fill valves. Flush tanks shall be equipped with an antisiphon fill valve conforming to ASSE 1002 or CSA B125.3. The fill valve backflow preventer shall be located at least 1 inch (25 mm) above the full opening of the overflow pipe.

P2902.4.2 Deck-mounted and integral vacuum breakers. *Approved* deck-mounted vacuum breakers and faucets with integral atmospheric or spill-proof vacuum breakers shall be installed in accordance with the manufacturer's installation instructions and the requirements for labeling with the critical level not less than 1 inch (25 mm) above the flood level rim.

**TABLE P2902.3
APPLICATION FOR BACKFLOW PREVENTERS**

DEVICE	DEGREE OF HAZARD ^a	APPLICATION ^b	APPLICABLE STANDARDS
Air gap	High or low hazard	Backsiphonage or backpressure	ASME A112.1.2
Air gap fittings for use with plumbing fixtures, appliances and appurtenances	High or low hazard	Backsiphonage or backpressure	ASME A112.1.3
Antisiphon-type fill valves for gravity water closet flush tanks	High hazard	Backsiphonage only	ASSE 1002, CSA B125.3
Backflow preventer with intermediate atmospheric vents	Low hazard	Backpressure or backsiphonage Sizes 1/4" – 3/4"	ASSE 1012, CSA B64.3
Double check backflow prevention assembly and double check fire protection backflow prevention assembly	Low hazard	Backpressure or backsiphonage Sizes 3/8" – 16"	ASSE 1015, AWWA C510, CSA B64.5, CSA B64.5.1
Double check detector fire protection backflow prevention assemblies	Low hazard	Backpressure or backsiphonage (Fire sprinkler systems) Sizes 2" – 16"	ASSE 1048
Dual-check-valve-type backflow preventer	Low hazard	Backpressure or backsiphonage Sizes 1/4" – 1"	ASSE 1024, CSA B64.6
Hose connection backflow preventer	High or low hazard	Low head backpressure, rated working pressure backpressure or backsiphonage Sizes 1/2" – 1"	ASSE 1052, CSA B64.2.1.1
Hose-connection vacuum breaker	High or low hazard	Low head backpressure or backsiphonage Sizes 1/2", 3/4", 1"	ASSE 1011, CSA B64.2, CSA B64.2.1
Laboratory faucet backflow preventer	High or low hazard	Low head backpressure and backsiphonage	ASSE 1035, CSA B64.7
Pipe-applied atmospheric-type vacuum breaker	High or low hazard	Backsiphonage only Sizes 1/4" – 4"	ASSE 1001, CSA B64.1.1
Pressure vacuum breaker assembly	High or low hazard	Backsiphonage only Sizes 1/2" – 2"	ASSE 1020, CSA B64.1.2
Reduced pressure detector fire protection backflow prevention assemblies	High or low hazard	Backsiphonage or backpressure (Fire sprinkler systems)	ASSE 1047
Reduced pressure principle backflow preventer and reduced pressure principle fire protection backflow preventer	High or low hazard	Backpressure or backsiphonage Sizes 3/8" – 16"	ASSE 1013, AWWA C511, CSA B64.4, CSA B64.4.1
Spillproof vacuum breaker	High or low hazard	Backsiphonage only Sizes 1/4" – 2"	ASSE 1056
Vacuum breaker wall hydrants, frost-resistant, automatic draining type	High or low hazard	Low head backpressure or backsiphonage Sizes 3/4" – 1"	ASSE 1019, CSA B64.2.2

For SI: 1 inch = 25.4 mm.

a. Low hazard—See Pollution (Section 202). High hazard—See Contamination (Section 202).

b. See Backpressure (Section 202). See Backpressure, Low Head (Section 202). See Backsiphonage (Section 202).

P2902.4.3 Hose connection. Sillcocks, hose bibbs, wall hydrants and other openings with a hose connection shall be protected by an atmospheric-type or pressure-type vacuum breaker or a permanently attached hose connection vacuum breaker.

Exceptions:

1. This section shall not apply to water heater and boiler drain valves that are provided with hose connection threads and that are intended only for tank or vessel draining.

2. This section shall not apply to water supply valves intended for connection of clothes washing machines where backflow prevention is otherwise provided or is integral with the machine.

P2902.5 Protection of potable water connections. Connections to the potable water shall conform to Sections P2902.5.1 through P2902.5.5.

P2902.5.1 Connections to boilers. The potable supply to the boiler shall be equipped with a backflow preventer with an intermediate atmospheric vent complying with ASSE 1012 or CSA B64.3. Where conditioning chemicals are

**TABLE P2902.3.1
MINIMUM AIR GAPS**

FIXTURE	MINIMUM AIR GAP	
	Away from a wall ^a (inches)	Close to a wall (inches)
Effective openings greater than 1 inch	Two times the diameter of the effective opening	Three times the diameter of the effective opening
Lavatories and other fixtures with effective opening not greater than 1/2 inch in diameter	1	1.5
Over-rim bath fillers and other fixtures with effective openings not greater than 1 inch in diameter	2	3
Sink, laundry trays, gooseneck back faucets and other fixtures with effective openings not greater than 3/4 inch in diameter	1.5	2.5

For SI: 1 inch = 25.4 mm.

a. Applicable where walls or obstructions are spaced from the nearest inside edge of the spout opening a distance greater than three times the diameter of the effective opening for a single wall, or a distance greater than four times the diameter of the effective opening for two intersecting walls.

introduced into the system, the potable water connection shall be protected by an air gap or a reduced pressure principle backflow preventer complying with ASSE 1013, CSA B64.4 or AWWA C511.

P2902.5.2 Heat exchangers. Heat exchangers using an essentially toxic transfer fluid shall be separated from the potable water by double-wall construction. An air gap open to the atmosphere shall be provided between the two walls. Heat exchangers utilizing an essentially nontoxic transfer fluid shall be permitted to be of single-wall construction.

P2902.5.3 Lawn irrigation systems. The potable water supply to lawn irrigation systems shall be protected against backflow by an atmospheric-type vacuum breaker, a pressure-type vacuum breaker or a reduced pressure principle backflow preventer. A valve shall not be installed downstream from an atmospheric vacuum breaker. Where chemicals are introduced into the system, the potable water supply shall be protected against backflow by a reduced pressure principle backflow preventer.

P2902.5.4 Connections to automatic fire sprinkler systems. The potable water supply to automatic fire sprinkler systems shall be protected against backflow by a double check-valve assembly or a reduced pressure principle backflow preventer.

Exception: Where systems are installed as a portion of the water distribution system in accordance with the requirements of this code and are not provided with a fire department connection, isolation of the water supply system shall not be required.

P2902.5.4.1 Additives or nonpotable source. Where systems contain chemical additives or antifreeze, or where systems are connected to a nonpotable secondary water supply, the potable water supply shall be protected against backflow by a reduced pressure principle

backflow preventer. Where chemical additives or antifreeze is added to only a portion of an automatic fire sprinkler or standpipe system, the reduced pressure principle backflow preventer shall be permitted to be located so as to isolate that portion of the system.

P2902.5.5 Solar systems. The potable water supply to a solar system shall be equipped with a backflow preventer with intermediate atmospheric vent complying with ASSE 1012 or a reduced pressure principle backflow preventer complying with ASSE 1013. Where chemicals are used, the potable water supply shall be protected by a reduced pressure principle backflow preventer.

Exception: Where all solar system piping is a part of the potable water distribution system, in accordance with the requirements of the *Florida Building Code, Plumbing*, and all components of the piping system are listed for potable water use, cross-connection protection measures shall not be required.

P2902.6 Location of backflow preventers. Access shall be provided to backflow preventers as specified by the manufacturer's installation instructions.

P2902.6.1 Outdoor enclosures for backflow prevention devices. Outdoor enclosures for backflow prevention devices shall comply with ASSE 1060.

P2902.6.2 Protection of backflow preventers. Backflow preventers shall not be located in areas subject to freezing except where they can be removed by means of unions, or are protected by heat, insulation or both.

P2902.6.3 Relief port piping. The termination of the piping from the relief port or air gap fitting of the backflow preventer shall discharge to an *approved* indirect waste receptor or to the outdoors where it will not cause damage or create a nuisance.

**SECTION P2903
WATER-SUPPLY SYSTEM**

P2903.1 Water supply system design criteria. The water service and water distribution systems shall be designed and pipe sizes shall be selected such that under conditions of peak demand, the capacities at the point of outlet discharge shall not be less than shown in Table P2903.1. Table P2903.2b shall be permitted to be used to size the water service or water distribution system.

**TABLE P2903.1
REQUIRED CAPACITIES AT
POINT OF OUTLET DISCHARGE**

FIXTURE AT POINT OF OUTLET	FLOW RATE (gpm)	FLOW PRESSURE (psi)
Bathtub, pressure-balanced or thermostatic mixing valve	4	20
Bidet, thermostatic mixing	2	20
Dishwasher	2.75	8
Laundry tub	4	8
Lavatory	2	8
Shower, pressure-balancing or thermostatic mixing valve	3	20
Sillcock, hose bibb	5	8
Sink	2.5	8
Water closet, flushometer tank	1.6	20
Water closet, tank, close coupled	3	20
Water closet, tank, one-piece	6	20

For SI: 1 gallon per minute = 3.785 L/m,
1 pound per square inch = 6.895 kPa.

P2903.2 Maximum flow and water consumption. The maximum water consumption flow rates and quantities for all plumbing fixtures and fixture fittings shall be in accordance with Table P2903.2.

**TABLE P2903.2
MAXIMUM FLOW RATES AND CONSUMPTION FOR
PLUMBING FIXTURES AND FIXTURE FITTINGS^a**

PLUMBING FIXTURE OR FIXTURE FITTING	PLUMBING FIXTURE OR FIXTURE FITTING
Lavatory faucet	2.2 gpm at 60 psi
Shower head ^a	2.5 gpm at 80 psi
Sink faucet	2.2 gpm at 60 psi
Water closet	1.6 gallons per flushing cycle

For SI: 1 gallon per minute = 3.785 L/m,
1 pound per square inch = 6.895 kPa.

- a. A handheld shower spray is also a shower head.
- b. Consumption tolerances shall be determined from referenced standards.

**TABLE P2903.2b
MINIMUM WATER SERVICE SIZE^a**

NO. OF FIXTURE UNITS FLUSH TANK WC ^b	DIAMETER OF WATER PIPE ^c	RECOMMENDED METER SIZE (inches) ^d	APPROX. PRESSURE LOSS METER + 100' PIPE (psi) ^e	NO. OF FIXTURE UNITS FLUSH VALVE WC ^b
18	3/4	5/8	30	—
19-55	1	1	30	—
—	1	1	30	9
56-85	1 1/4	1	30	—
—	1 1/4	1	30	10-20
86-225	1 1/2	1 1/2	30	—
—	1 1/2	1 1/2	30	21-77
226-350	2	1 1/2	30	—
—	2	1 1/2	30	78-175
351-550	2	2	30	—
—	2	2	30	176-315
551-640	2 1/2	2	30	—
—	2 1/2	2	30	316-392
641-1340	3	3	22	—
—	3	3	22	393-940

- a. Table is applicable for both copper and plastic water piping.
- b. See Table P3004.1 for fixture unit values.
- c. Minimum water service shall be 3/4" to control valve.
- d. All secondary submeters and backflow assemblies shall be at least the same size as the line in which they are installed.
- e. Table based on minimum water main pressure of 50 psi.

P2903.3 Minimum pressure. Minimum static pressure (as determined by the local water authority) at the building entrance for either public or private water service shall be 40 psi (276 kPa).

P2903.3.1 Maximum pressure. Maximum static pressure shall be 80 psi (551 kPa). When main pressure exceeds 80 psi (551 kPa), an *approved* pressure-reducing valve conforming to ASSE 1003 shall be installed on the domestic water branch main or riser at the connection to the water-service pipe.

P2903.4 Thermal expansion control. A means for controlling increased pressure caused by thermal expansion shall be installed where required in accordance with Sections P2903.4.1 and P2903.4.2.

P2903.4.1 Pressure-reducing valve. For water service system sizes up to and including 2 inches (51 mm), a device for controlling pressure shall be installed where, because of thermal expansion, the pressure on the downstream side of a pressure-reducing valve exceeds the pressure-reducing valve setting.

P2903.4.2 Backflow prevention device or check valve. Where a backflow prevention device, check valve or other device is installed on a water supply system using storage water heating equipment such that thermal expansion

**TABLE P2903.6
WATER-SUPPLY FIXTURE-UNIT VALUES FOR VARIOUS PLUMBING FIXTURES AND FIXTURE GROUPS**

TYPE OF FIXTURES OR GROUP OF FIXTURES	WATER-SUPPLY FIXTURE-UNIT VALUE (w.s.f.u.)		
	Hot	Cold	Combined
Bath tub (with/without overhead shower head)	1.0	1.0	1.4
Clothes washer	1.0	1.0	1.4
Dishwasher	1.4	—	1.4
Full-bath group with bathtub (with/without shower head) or shower stall	1.5	2.7	3.6
Half-bath group (water closet and lavatory)	0.5	2.5	2.6
Hose bibb (sillcock) ^a	—	2.5	2.5
Kitchen group (dishwasher and sink with/without garbage grinder)	1.9	1.0	2.5
Kitchen sink	1.0	1.0	1.4
Laundry group (clothes washer standpipe and laundry tub)	1.8	1.8	2.5
Laundry tub	1.0	1.0	1.4
Lavatory	0.5	0.5	0.7
Shower stall	1.0	1.0	1.4
Water closet (tank type)	—	2.2	2.2

For SI: 1 gallon per minute = 3.785 L/m.

a. The fixture unit value 2.5 assumes a flow demand of 2.5 gpm, such as for an individual lawn sprinkler device. If a hose bibb/sill cock will be required to furnish a greater flow, the equivalent fixture-unit value may be obtained from this table or Table P2903.6(1).

causes an increase in pressure, a device for controlling pressure shall be installed.

P2903.5 Water hammer. The flow velocity of the water distribution system shall be controlled to reduce the possibility of water hammer. Water-hammer arrestors shall be installed in accordance with the manufacturer’s installation instructions. Water hammer arrestors shall conform to ASSE 1010.

P2903.6 Determining water-supply fixture units. Supply loads in the building water-distribution system shall be determined by total load on the pipe being sized, in terms of water-supply fixture units (w.s.f.u.), as shown in Table P2903.6, and gallon per minute (gpm) flow rates [see Table P2903.6(1)]. For fixtures not listed, choose a w.s.f.u. value of a fixture with similar flow characteristics.

P2903.7 Size of water-service mains, branch mains and risers. The minimum size water service pipe shall be $\frac{3}{4}$ inch (19 mm). The size of water service mains, branch mains and risers shall be determined according to water supply demand [gpm (L/m)], available water pressure [psi (kPa)] and friction loss caused by the water meter and *developed length* of pipe [feet (m)], including *equivalent length* of fittings. The size of each water distribution system shall be determined according to design methods conforming to acceptable engineering practice, such as those methods in Appendix P and shall be *approved* by the code official.

P2903.8 Gridded and parallel water distribution system manifolds. Hot water and cold water manifolds installed with gridded or parallel-connected individual distribution lines to each fixture or fixture fittings shall be designed in accordance with Sections P2903.8.1 through P2903.8.6.

P2903.8.1 Sizing of manifolds. Manifolds shall be sized in accordance with Table P2903.8.1. Total gallons per minute is the demand for all outlets.

P2903.8.2 Minimum size. Where the *developed length* of the distribution line is 60 feet (18 288 mm) or less, and the available pressure at the meter is a minimum of 40 pounds per square inch (276 kPa), the minimum size of individual distribution lines shall be $\frac{3}{8}$ inch (10 mm). Certain fixtures such as one-piece water closets and whirlpool bathtubs shall require a larger size where specified by the manufacturer. If a water heater is fed from the end of a cold water manifold, the manifold shall be one size larger than the water heater feed.

P2903.8.3 Orientation. Manifolds shall be permitted to be installed in a horizontal or vertical position.

P2903.8.4 Support and protection. Plastic piping bundles shall be secured in accordance with the manufacturer’s installation instructions and supported in accordance with Section P2605. Bundles that have a change in direction equal to or greater than 45 degrees (0.79 rad) shall be protected from chafing at the point of contact with framing members by sleeving or wrapping.

P2903.8.5 Valving. Fixture valves, when installed, shall be located either at the fixture or at the manifold. If valves are installed at the manifold, they shall be labeled indicating the fixture served.

P2903.8.6 Hose bibb bleed. A *readily accessible* air bleed shall be installed in hose bibb supplies at the manifold or at the hose bibb exit point.

**TABLE P2903.6(1)
CONVERSIONS FROM WATER SUPPLY FIXTURE UNIT TO GALLON PER MINUTE FLOW RATES**

SUPPLY SYSTEMS PREDOMINANTLY FOR FLUSH TANKS			SUPPLY SYSTEM PREDOMINANTLY FOR FLUSH VALVES		
Load	Demand		Load	Demand	
(Water supply fixture units)	(Gallons per minute)	(Cubic feet per minute)	(Water supply fixture units)	(Gallons per minute)	(Cubic feet per minute)
1	3.0	0.04104	—	—	—
2	5.0	0.0684	—	—	—
3	6.5	0.86892	—	—	—
4	8.0	1.06944	—	—	—
5	9.4	1.256592	5	15.0	2.0052
6	10.7	1.430376	6	17.4	2.326032
7	11.8	1.577424	7	19.8	2.646364
8	12.8	1.711104	8	22.2	2.967696
9	13.7	1.831416	9	24.6	3.288528
10	14.6	1.951728	10	27.0	3.60936
11	15.4	2.058672	11	27.8	3.716304
12	16.0	2.13888	12	28.6	3.823248
13	16.5	2.20572	13	29.4	3.930192
14	17.0	2.27256	14	30.2	4.037136
15	17.5	2.3394	15	31.0	4.14408
16	18.0	2.90624	16	31.8	4.241024
17	18.4	2.459712	17	32.6	4.357968
18	18.8	2.513184	18	33.4	4.464912
19	19.2	2.566656	19	34.2	4.571856
20	19.6	2.620128	20	35.0	4.6788
25	21.5	2.87412	25	38.0	5.07984
30	23.3	3.114744	30	42.0	5.61356
35	24.9	3.328632	35	44.0	5.88192
40	26.3	3.515784	40	46.0	6.14928
45	27.7	3.702936	45	48.0	6.41664
50	29.1	3.890088	50	50.0	6.684

For SI: 1 gallon per minute = 3.785 L/m, 1 cubic foot per minute = 0.4719 L/s.

**TABLE P2903.8.1
MANIFOLD SIZING**

PLASTIC		METALLIC	
Nominal Size ID (inches)	Maximum ^a gpm	Nominal Size ID (inches)	Maximum ^a gpm
3/4	17	3/4	11
1	29	1	20
1 1/4	46	1 1/4	31
1 1/2	66	1 1/2	44

For SI: 1 inch = 25.4 mm, 1 gallon per minute = 3.785 L/m, 1 foot per second = 0.3048 m/s.

NOTE: See Table P2903.6 for w.s.f.u and Table P2903.6(1) for gallon-per-minute (gpm) flow rates.

a. Based on velocity limitation: plastic—12 fps; metal—8 fps.

P2903.9 Valves. Valves shall be installed in accordance with Sections P2903.9.1 through P2903.9.5.

P2903.9.1 Service valve. Each *dwelling unit* shall be provided with an accessible main shutoff valve near the entrance of the water service. The valve shall be of a full-open type having nominal restriction to flow, with provision for drainage such as a bleed orifice or installation of a separate drain valve. Additionally, the water service shall be valved at the curb or property line in accordance with local requirements.

P2903.9.2 Water heater valve. A *readily accessible* full-open valve shall be installed in the cold-water supply pipe to each water heater at or near the water heater.

P2903.9.3 Fixture valves and access. Valves serving individual fixtures, *appliances*, risers and branches shall be provided with access. An individual shutoff valve shall be required on the fixture supply pipe to each plumbing fixture other than bathtubs and showers.

P2903.9.4 Valve requirements. Valves shall be of an *approved* type and compatible with the type of piping material installed in the system. Ball valves, gate valves, globe valves and plug valves intended to supply drinking water shall meet the requirements of NSF 61.

P2903.9.5 Valves and outlets prohibited below grade. Potable water outlets and combination stop-and-waste valves shall not be installed underground or below grade. Freezeproof yard hydrants that drain the riser into the ground are considered to be stop-and-waste valves.

Exception: Installation of freezeproof yard hydrants that drain the riser into the ground shall be permitted if the potable water supply to such hydrants is protected upstream of the hydrants in accordance with Section P2902 and the hydrants are permanently identified as nonpotable outlets by *approved* signage that reads as follows: "Caution, Nonpotable Water. Do Not Drink."

P2903.10 Hose bibb. Hose bibbs subject to freezing, including the "frost-proof" type, shall be equipped with an accessible stop-and-waste-type valve inside the building so that they can be controlled and/or drained during cold periods.

Exception: Frostproof hose bibbs installed such that the stem extends through the building insulation into an open heated or *semiconditioned space* need not be separately valved (see Figure P2903.10).

**SECTION P2904
DWELLING UNIT FIRE SPRINKLER SYSTEMS**

P2904.1 General. Where installed, residential fire sprinkler systems, or portions thereof, shall be in accordance with NFPA 13D or Section P2904, which shall be considered equivalent to NFPA 13D. Section P2904 shall apply to stand-alone and multipurpose wet-pipe sprinkler systems that do not include the use of antifreeze. A multipurpose fire sprinkler system shall supply domestic water to both fire sprinklers and plumbing fixtures. A stand-alone sprinkler system shall be separate and independent from the water distribution system. A backflow preventer shall not be required to separate a stand-alone sprinkler system from the water distribution system.

P2904.1.1 Required sprinkler locations. Sprinklers shall be installed to protect all areas of a *dwelling unit*.

Exceptions:

1. Attics, crawl spaces and normally unoccupied concealed spaces that do not contain fuel-fired appliances do not require sprinklers. In *attics*, crawl spaces and normally unoccupied concealed spaces that contain fuel-fired equipment, a sprinkler shall be installed above the equipment; however, sprinklers shall not be required in the remainder of the space.
2. Clothes closets, linen closets and pantries not exceeding 24 square feet (2.2 m²) in area, with the

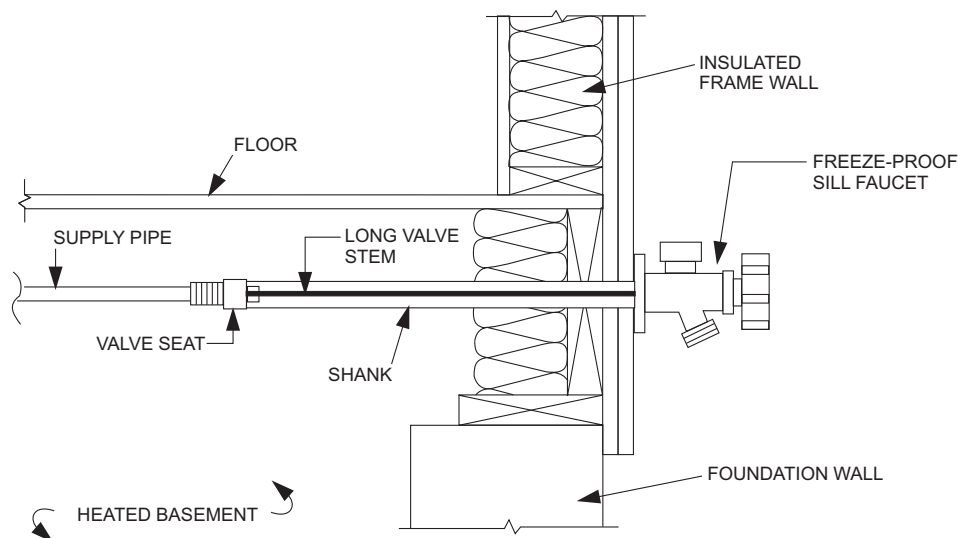

**FIGURE P2903.10
TYPICAL FROSTPROOF HOSE BIBB INSTALLATION NOT REQUIRING SEPARATE VALVE**

**TABLE P2904.2.2
LOCATIONS WHERE INTERMEDIATE TEMPERATURE SPRINKLERS ARE REQUIRED**

HEAT SOURCE	RANGE OF DISTANCE FROM HEAT SOURCE WITHIN WHICH INTERMEDIATE TEMPERATURE SPRINKLERS ARE REQUIRED ^{a,b} (inches)
Fireplace, side of open or recessed fireplace	12 to 36
Fireplace, front of recessed fireplace	36 to 60
Coal and wood burning stove	12 to 42
Kitchen range top	9 to 18
Oven	9 to 18
Vent connector or chimney connector	9 to 18
Heating duct, not insulated	9 to 18
Hot water pipe, not insulated	6 to 12
Side of ceiling or wall warm air register	12 to 24
Front of wall mounted warm air register	18 to 36
Water heater, furnace or boiler	3 to 6
Luminaire up to 250 watts	3 to 6
Luminaire 250 watts up to 499 watts	6 to 12

For SI: 1 inch = 25.4 mm.

- a. Sprinklers shall not be located at distances less than the minimum table distance unless the sprinkler listing allows a lesser distance.
- b. Distances shall be measured in a straight line from the nearest edge of the heat source to the nearest edge of the sprinkler

smallest dimension not greater than 3 feet (915 mm) and having wall and ceiling surfaces of gypsum board.

- 3. Bathrooms not more than 55 square feet (5.1 m²) in area.
- 4. Garages; carports; exterior porches; unheated entry areas, such as mud rooms, that are adjacent to an exterior door; and similar areas.

P2904.2 Sprinklers. Sprinklers shall be new listed residential sprinklers and shall be installed in accordance with the sprinkler manufacturer’s installation instructions.

P2904.2.1 Temperature rating and separation from heat sources. Except as provided for in Section P2904.2.2, sprinklers shall have a temperature rating of not less than 135°F (57°C) and not more than 170°F (77°C). Sprinklers shall be separated from heat sources as required by the sprinkler manufacturer’s installation instructions.

P2904.2.2 Intermediate temperature sprinklers. Sprinklers shall have an intermediate temperature rating not less than 175°F (79°C) and not more than 225°F (107°C) where installed in the following locations:

- 1. Directly under skylights, where the sprinkler is exposed to direct sunlight.
- 2. In *attics*.
- 3. In concealed spaces located directly beneath a roof.
- 4. Within the distance to a heat source as specified in Table P2904.2.2

P2904.2.3 Freezing areas. Piping shall be protected from freezing as required by Section P2603.6. Where sprinklers are required in areas that are subject to freezing, dry-side-

wall or dry-pendent sprinklers extending from a nonfreezing area into a freezing area shall be installed.

P2904.2.4 Sprinkler coverage. Sprinkler coverage requirements and sprinkler obstruction requirements shall be in accordance with Sections P2904.2.4.1 and P2904.2.4.2.

P2904.2.4.1 Coverage area limit. The area of coverage of a single sprinkler shall not exceed 400 square feet (37 m²) and shall be based on the sprinkler listing and the sprinkler manufacturer’s installation instructions.

P2904.2.4.2 Obstructions to coverage. Sprinkler discharge shall not be blocked by obstructions unless additional sprinklers are installed to protect the obstructed area. Sprinkler separation from obstructions shall comply with the minimum distances specified in the sprinkler manufacturer’s instructions.

P2904.2.4.2.1 Additional requirements for pendent sprinklers. Pendent sprinklers within 3 feet (915 mm) of the center of a ceiling fan, surface-mounted ceiling luminaire or similar object shall be considered to be obstructed, and additional sprinklers shall be installed.

P2904.2.4.2.2 Additional requirements for sidewall sprinklers. Sidewall sprinklers within 5 feet (1524 mm) of the center of a ceiling fan, surface-mounted ceiling luminaire or similar object shall be considered to be obstructed, and additional sprinklers shall be installed.

P2904.2.5 Sprinkler installation on systems assembled with solvent cement. The solvent cementing of threaded adapter fittings shall be completed and threaded adapters for sprinklers shall be verified as being clear of excess cement prior to the installation of sprinklers on systems assembled with solvent cement.

P2904.2.6 Sprinkler modifications prohibited. Painting, caulking or modifying of sprinklers shall be prohibited. Sprinklers that have been painted, caulked, modified or damaged shall be replaced with new sprinklers.

P2904.3 Sprinkler piping system. Sprinkler piping shall be supported in accordance with the requirements for cold water distribution piping. Sprinkler piping shall comply with all requirements for cold water distribution piping. For multipurpose piping systems, the sprinkler piping shall connect to and be a part of the cold water distribution piping system.

P2904.3.1 Nonmetallic pipe and tubing. Nonmetallic pipe and tubing, such as CPVC and PEX, shall be listed for use in residential fire sprinkler systems.

P2904.3.1.1 Nonmetallic pipe protection. Nonmetallic pipe and tubing systems shall be protected from exposure to the living space by a layer of not less than $\frac{3}{8}$ inch (9.5 mm) thick gypsum wallboard, $\frac{1}{2}$ inch thick plywood (13 mm), or other material having a 15 minute fire rating.

Exceptions:

1. Pipe protection shall not be required in areas that do not require protection with sprinklers as specified in Section P2904.1.1.
2. Pipe protection shall not be required where exposed piping is permitted by the pipe listing.

P2904.3.2 Shutoff valves prohibited. With the exception of shutoff valves for the entire water distribution system, valves shall not be installed in any location where the valve would isolate piping serving one or more sprinklers.

P2904.3.3 Single dwelling limit. Piping beyond the service valve located at the beginning of the water distribution system shall not serve more than one *dwelling*.

P2904.3.4 Drain. A means to drain the sprinkler system shall be provided on the system side of the water distribution shutoff valve.

P2904.4 Determining system design flow. The flow for sizing the sprinkler piping system shall be based on the flow rating of each sprinkler in accordance with Section P2904.4.1 and the calculation in accordance with Section P2904.4.2.

P2904.4.1 Determining required flow rate for each sprinkler. The minimum required flow for each sprinkler shall be determined using the sprinkler manufacturer's published data for the specific sprinkler model based on all of the following:

1. The area of coverage.
2. The ceiling configuration.
3. The temperature rating.
4. Any additional conditions specified by the sprinkler manufacturer.

P2904.4.2 System design flow rate. The design flow rate for the system shall be based on the following:

1. The design flow rate for a room having only one sprinkler shall be the flow rate required for that sprinkler, as determined by Section P2904.4.1.

2. The design flow rate for a room having two or more sprinklers shall be determined by identifying the sprinkler in that room with the highest required flow rate, based on Section P2904.4.1, and multiplying that flow rate by 2.
3. Where the sprinkler manufacturer specifies different criteria for ceiling configurations that are not smooth, flat and horizontal, the required flow rate for that room shall comply with the sprinkler manufacturer's instructions.
4. The design flow rate for the sprinkler system shall be the flow required by the room with the largest flow rate, based on Items 1, 2 and 3.
5. For the purpose of this section, it shall be permissible to reduce the design flow rate for a room by subdividing the space into two or more rooms, where each room is evaluated separately with respect to the required design flow rate. Each room shall be bounded by walls and a ceiling. Openings in walls shall have a lintel not less than 8 inches (203 mm) in depth and each lintel shall form a solid barrier between the ceiling and the top of the opening.

P2904.5 Water supply. The water supply shall provide not less than the required design flow rate for sprinklers in accordance with Section P2904.4.2 at a pressure not less than that used to comply with Section P2904.6.

P2904.5.1 Water supply from individual sources. Where a *dwelling unit* water supply is from a tank system, a private well system or a combination of these, the available water supply shall be based on the minimum pressure control setting for the pump.

P2904.5.2 Required capacity. The water supply shall have the capacity to provide the required design flow rate for sprinklers for a period of time as follows:

1. 7 minutes for *dwelling units* one *story* in height and less than 2,000 square feet (186 m²) in area.
2. 10 minutes for *dwelling units* two or more stories in height or equal to or greater than 2,000 square feet (186 m²) in area.

Where a well system, a water supply tank system or a combination thereof is used, any combination of well capacity and tank storage shall be permitted to meet the capacity requirement.

P2904.6 Pipe sizing. The piping to sprinklers shall be sized for the flow required by Section P2904.4.2. The flow required to supply the plumbing fixtures shall not be required to be added to the sprinkler design flow.

P2904.6.1 Method of sizing pipe. Piping supplying sprinklers shall be sized using the prescriptive method in Section P2904.6.2 or by hydraulic calculation in accordance with NFPA 13D. The minimum pipe size from the water supply source to any sprinkler shall be $\frac{3}{4}$ inch (19 mm) nominal. Threaded adapter fittings at the point where sprinklers are attached to the piping shall be a minimum of $\frac{1}{2}$ inch (13 mm) nominal.

P2904.6.2 Prescriptive pipe sizing method. Pipe shall be sized by determining the available pressure to offset friction loss in piping and identifying a piping material, diameter

and length using the equation in Section P2904.6.2.1 and the procedure in Section P2904.6.2.2.

P2904.6.2.1 Available pressure equation. The pressure available to offset friction loss in the interior piping system (P_t) shall be determined in accordance with the Equation 29-1.

$$P_t = P_{sup} - PL_{svc} - PL_m - PL_d - PL_e - P_{sp} \quad \text{(Equation 29-1)}$$

where:

P_t = Pressure used in applying Tables P2904.6.2(4) through P2904.6.2(9).

P_{sup} = Pressure available from the water supply source.

PL_{svc} = Pressure loss in the water-service pipe.

PL_m = Pressure loss in the water meter.

PL_d = Pressure loss from devices other than the water meter.

PL_e = Pressure loss associated with changes in elevation.

P_{sp} = Maximum pressure required by a sprinkler.

2904.6.2.2 Calculation procedure. Determination of the required size for water distribution piping shall be in accordance with the following procedure:

Step 1—Determine P_{sup}

Obtain the static supply pressure that will be available from the water main from the water purveyor, or for an individual source, the available supply pressure shall be in accordance with Section P2904.5.1.

Step 2—Determine PL_{svc}

Use Table P2904.6.2(1) to determine the pressure loss in the water service pipe based on the selected size of the water service.

Step 3—Determine PL_m

Use Table P2904.6.2(2) to determine the pressure loss from the water meter, based on the selected water meter size.

Step 4—Determine PL_d

Determine the pressure loss from devices other than the water meter installed in the piping system supplying sprinklers, such as pressure-reducing valves, backflow preventers, water softeners or water filters. Device pressure losses shall be based on the device manufacturer's specifications. The flow rate used to determine pressure loss shall be the rate from Section P2904.4.2, except that 5 gpm (0.3 L/S) shall be added where the device is installed in a water-service pipe that supplies more than one *dwelling*. As alternative to deducting pressure loss for a device, an automatic bypass valve shall be installed to divert flow around the device when a sprinkler activates.

Step 5—Determine PL_e

Use Table P2904.6.2(3) to determine the pressure loss associated with changes in elevation. The elevation used

in applying the table shall be the difference between the elevation where the water source pressure was measured and the elevation of the highest sprinkler.

Step 6—Determine P_{sp}

Determine the maximum pressure required by any individual sprinkler based on the flow rate from Section P2904.4.1. The required pressure is provided in the sprinkler manufacturer's published data for the specific sprinkler model based on the selected flow rate.

Step 7—Calculate P_t

Using Equation 29-1, calculate the pressure available to offset friction loss in water-distribution piping between the service valve and the sprinklers.

Step 8—Determine the maximum allowable pipe length

Use Tables P2904.6.2(4) through P2904.6.2(9) to select a material and size for water distribution piping. The piping material and size shall be acceptable if the *developed length* of pipe between the service valve and the most remote sprinkler does not exceed the maximum allowable length specified by the applicable table. Interpolation of P_t between the tabular values shall be permitted.

The maximum allowable length of piping in Tables P2904.6.2(4) through P2904.6.2(9) incorporates an adjustment for pipe fittings, and no additional consideration of friction losses associated with pipe fittings shall be required.

P2904.7 Instructions and signs. An owner's manual for the fire sprinkler system shall be provided to the owner. A sign or valve tag shall be installed at the main shutoff valve to the water distribution system stating the following: "Warning, the water system for this home supplies fire sprinklers that require certain flows and pressures to fight a fire. Devices that restrict the flow or decrease the pressure or automatically shut off the water to the fire sprinkler system, such as water softeners, filtration systems and automatic shutoff valves, shall not be added to this system without a review of the fire sprinkler system by a fire protection specialist. Do not remove this sign."

P2904.8 Inspections. The water distribution system shall be inspected in accordance with Sections P2904.8.1 and P2904.8.2.

P2904.8.1 Preconcealment inspection. The following items shall be verified prior to the concealment of any sprinkler system piping:

1. Sprinklers are installed in all areas as required by Section P2904.1.1.
2. Where sprinkler water spray patterns are obstructed by construction features, luminaires or ceiling fans, additional sprinklers are installed as required by Section P2904.2.4.2.
3. Sprinklers are the correct temperature rating and are installed at or beyond the required separation distances from heat sources as required by Sections P2904.2.1 and P2904.2.2.
4. The pipe size equals or exceeds the size used in applying Tables P2904.6.2(4) through P2904.6.2(9) or, if the piping system was hydraulically calculated in

TABLE P2904.6.2(1)
WATER SERVICE PRESSURE LOSS (PL_{svc})^{a,b}

FLOW RATE ^c (gpm)	³ / ₄ INCH WATER SERVICE PRESSURE LOSS (psi)				1 INCH WATER SERVICE PRESSURE LOSS (psi)				1 ¹ / ₄ INCH WATER SERVICE PRESSURE LOSS (psi)			
	Length of water service pipe (feet)				Length of water service pipe (feet)				Length of water service pipe (feet)			
	40 or less	41 to 75	76 to 100	101 to 150	40 or less	41 to 75	76 to 100	101 to 150	40 or less	41 to 75	76 to 100	101 to 150
8	5.1	8.7	11.8	17.4	1.5	2.5	3.4	5.1	0.6	1.0	1.3	1.9
10	7.7	13.1	17.8	26.3	2.3	3.8	5.2	7.7	0.8	1.4	2.0	2.9
12	10.8	18.4	24.9	NP	3.2	5.4	7.3	10.7	1.2	2.0	2.7	4.0
14	14.4	24.5	NP	NP	4.2	7.1	9.6	14.3	1.6	2.7	3.6	5.4
16	18.4	NP	NP	NP	5.4	9.1	12.4	18.3	2.0	3.4	4.7	6.9
18	22.9	NP	NP	NP	6.7	11.4	15.4	22.7	2.5	4.3	5.8	8.6
20	27.8	NP	NP	NP	8.1	13.8	18.7	27.6	3.1	5.2	7.0	10.4
22	NP	NP	NP	NP	9.7	16.5	22.3	NP	3.7	6.2	8.4	12.4
24	NP	NP	NP	NP	11.4	19.3	26.2	NP	4.3	7.3	9.9	14.6
26	NP	NP	NP	NP	13.2	22.4	NP	NP	5.0	8.5	11.4	16.9
28	NP	NP	NP	NP	15.1	25.7	NP	NP	5.7	9.7	13.1	19.4
30	NP	NP	NP	NP	17.2	NP	NP	NP	6.5	11.0	14.9	22.0
32	NP	NP	NP	NP	19.4	NP	NP	NP	7.3	12.4	16.8	24.8
34	NP	NP	NP	NP	21.7	NP	NP	NP	8.2	13.9	18.8	NP
36	NP	NP	NP	NP	24.1	NP	NP	NP	9.1	15.4	20.9	NP

For SI: 1 inch = 25.4 mm, 1 foot = 304.8 mm, 1 gallon per minute = 0.063 L/s, 1 pound per square inch = 6.895 kPa.

NP - Not permitted. Pressure loss exceeds reasonable limits.

- a. Values are applicable for underground piping materials listed in Table P2905.4 and are based on an SDR of 11 and a Hazen Williams C Factor of 150.
- b. Values include the following length allowances for fittings: 25% length increase for actual lengths up to 100 feet and 15% length increase for actual lengths over 100 feet.
- c. Flow rate from Section P2904.4.2. Add 5 gpm to the flow rate required by Section P2904.4.2 where the water-service pipe supplies more than one dwelling.

TABLE P2904.6.2(2)
MINIMUM WATER METER PRESSURE LOSS (PL_m)^a

FLOW RATE (gallons per minute, gpm) ^b	⁵ / ₈ -INCH METER PRESSURE LOSS (pounds per square inch, psi)	³ / ₄ -INCH METER PRESSURE LESS (pounds per square inch, psi)	1-INCH METER PRESSURE LOSS (pounds per square inch, psi)
8	2	1	1
10	3	1	1
12	4	1	1
14	5	2	1
16	7	3	1
18	9	4	1
20	11	4	2
22	NP	5	2
24	NP	5	2
26	NP	6	2
28	NP	6	2
30	NP	7	2
32	NP	7	3
34	NP	8	3
36	NP	8	3

For SI: 1 inch = 25.4 mm, 1 pound per square inch = 6.895 kPa, 1 gallon per minute = 0.063 L/s.

NP - Not permitted unless the actual water meter pressure loss is known.

- a. Table P2904.6.2(2) establishes conservative values for water meter pressure loss or installations where the water meter loss is unknown. Where the actual water meter pressure loss is known, P_m shall be the actual loss.
- b. Flow rate from Section P2904.4.2. Add 5 gpm to the flow rate required by Section P2904.4.2 where the water-service pipe supplies more than one dwelling.

TABLE P2904.6.2(3)
ELEVATION LOSS (PL_e)

ELEVATION (feet)	PRESSURE LOSS (psi)
5	2.2
10	4.4
15	6.5
20	8.7
25	10.9
30	13
35	15.2
40	17.4

For SI: 1 foot = 304.8 mm, 1 pound per square inch = 6.895 kPa.

TABLE P2904.6.2(4)
ALLOWABLE PIPE LENGTH FOR 3/4-INCH TYPE M COPPER WATER TUBING

SPRINKLER FLOW RATE ^a (gpm)	WATER DISTRIBUTION SIZE (inch)	AVAILABLE PRESSURE - P _t (psi)									
		15	20	25	30	35	40	45	50	55	60
		Allowable length of pipe from service valve to farthest sprinkler (feet)									
8	3/4	217	289	361	434	506	578	650	723	795	867
9	3/4	174	232	291	349	407	465	523	581	639	697
10	3/4	143	191	239	287	335	383	430	478	526	574
11	3/4	120	160	200	241	281	321	361	401	441	481
12	3/4	102	137	171	205	239	273	307	341	375	410
13	3/4	88	118	147	177	206	235	265	294	324	353
14	3/4	77	103	128	154	180	205	231	257	282	308
15	3/4	68	90	113	136	158	181	203	226	248	271
16	3/4	60	80	100	120	140	160	180	200	220	241
17	3/4	54	72	90	108	125	143	161	179	197	215
18	3/4	48	64	81	97	113	129	145	161	177	193
19	3/4	44	58	73	88	102	117	131	146	160	175
20	3/4	40	53	66	80	93	106	119	133	146	159
21	3/4	36	48	61	73	85	97	109	121	133	145
22	3/4	33	44	56	67	78	89	100	111	122	133
23	3/4	31	41	51	61	72	82	92	102	113	123
24	3/4	28	38	47	57	66	76	85	95	104	114
25	3/4	26	35	44	53	61	70	79	88	97	105
26	3/4	24	33	41	49	57	65	73	82	90	98
27	3/4	23	30	38	46	53	61	69	76	84	91
28	3/4	21	28	36	43	50	57	64	71	78	85
29	3/4	20	27	33	40	47	53	60	67	73	80
30	3/4	19	25	31	38	44	50	56	63	69	75
31	3/4	18	24	29	35	41	47	53	59	65	71
32	3/4	17	22	28	33	39	44	50	56	61	67
33	3/4	16	21	26	32	37	42	47	53	58	63
34	3/4	NP	20	25	30	35	40	45	50	55	60
35	3/4	NP	19	24	28	33	38	42	47	52	57
36	3/4	NP	18	22	27	31	36	40	45	49	54
37	3/4	NP	17	21	26	30	34	38	43	47	51
38	3/4	NP	16	20	24	28	32	36	40	45	49
39	3/4	NP	15	19	23	27	31	35	39	42	46
40	3/4	NP	NP	18	22	26	29	33	37	40	44

For SI: 1 inch = 25.4 mm, 1 foot = 304.8 mm, 1 pound per square inch = 6.895 kPa, 1 gallon per minute = 0.963 L/s.

NP - Not permitted

a. Flow rate from Section P2904.4.2.

**TABLE P2904.6.2(5)
ALLOWABLE PIPE LENGTH FOR 1-INCH TYPE M COPPER WATER TUBING**

SPRINKLER FLOW RATE ^a (gpm)	WATER DISTRIBUTION SIZE (inch)	AVAILABLE PRESSURE - P_t (psi)									
		15	20	25	30	35	40	45	50	55	60
		Allowable length of pipe from service valve to farthest sprinkler (feet)									
8	1	806	1075	1343	1612	1881	2149	2418	2687	2955	3224
9	1	648	864	1080	1296	1512	1728	1945	2161	2377	2593
10	1	533	711	889	1067	1245	1422	1600	1778	1956	2134
11	1	447	586	745	894	1043	1192	1341	1491	1640	1789
12	1	381	508	634	761	888	1015	1142	1269	1396	1523
13	1	328	438	547	657	766	875	985	1094	1204	1313
14	1	286	382	477	572	668	763	859	954	1049	1145
15	1	252	336	420	504	588	672	756	840	924	1008
16	1	224	298	373	447	522	596	671	745	820	894
17	1	200	266	333	400	466	533	600	666	733	799
18	1	180	240	300	360	420	479	539	599	659	719
19	1	163	217	271	325	380	434	488	542	597	651
20	1	148	197	247	296	345	395	444	493	543	592
21	1	135	180	225	270	315	360	406	451	496	541
22	1	124	165	207	248	289	331	372	413	455	496
23	1	114	152	190	228	267	305	343	381	419	457
24	1	106	141	176	211	246	282	317	352	387	422
25	1	98	131	163	196	228	261	294	326	359	392
26	1	91	121	152	182	212	243	273	304	334	364
27	1	85	113	142	170	198	226	255	283	311	340
28	1	79	106	132	159	185	212	238	265	291	318
29	1	74	99	124	149	174	198	223	248	273	298
30	1	70	93	116	140	163	186	210	233	256	280
31	1	66	88	110	132	153	175	197	219	241	263
32	1	62	83	103	124	145	165	186	207	227	248
33	1	59	78	98	117	137	156	176	195	215	234
34	1	55	74	92	111	129	148	166	185	203	222
35	1	53	70	88	105	123	140	158	175	193	210
36	1	50	66	83	100	116	133	150	166	183	199
37	1	47	63	79	95	111	126	142	158	174	190
38	1	45	60	75	90	105	120	135	150	165	181
39	1	43	57	72	86	100	115	129	143	158	172
40	1	41	55	68	82	96	109	123	137	150	164

For SI: 1 inch = 25.4 mm, 1 foot = 304.8 mm, 1 pound per square inch = 6.895 kPa, 1 gallon per minute = 0.963 L/s.

a. Flow rate from Section P2904.4.2.

TABLE P2904.6.2(6)
ALLOWABLE PIPE LENGTH FOR 3/4-INCH CPVC PIPE

SPRINKLER FLOW RATE ^a (gpm)	WATER DISTRIBUTION SIZE (inch)	AVAILABLE PRESSURE - P _t (psi)									
		15	20	25	30	35	40	45	50	55	60
		Allowable length of pipe from service valve to farthest sprinkler (feet)									
8	3/4	348	465	581	697	813	929	1045	1161	1278	1394
9	3/4	280	374	467	560	654	747	841	934	1027	1121
10	3/4	231	307	384	461	538	615	692	769	845	922
11	3/4	193	258	322	387	451	515	580	644	709	773
12	3/4	165	219	274	329	384	439	494	549	603	658
13	3/4	142	189	237	284	331	378	426	473	520	568
14	3/4	124	165	206	247	289	330	371	412	454	495
15	3/4	109	145	182	218	254	290	327	363	399	436
16	3/4	97	129	161	193	226	258	290	322	354	387
17	3/4	86	115	144	173	202	230	259	288	317	346
18	3/4	78	104	130	155	181	207	233	259	285	311
19	3/4	70	94	117	141	164	188	211	234	258	281
20	3/4	64	85	107	128	149	171	192	213	235	256
21	3/4	58	78	97	117	136	156	175	195	214	234
22	3/4	54	71	89	107	125	143	161	179	197	214
23	3/4	49	66	82	99	115	132	148	165	181	198
24	3/4	46	61	76	91	107	122	137	152	167	183
25	3/4	42	56	71	85	99	113	127	141	155	169
26	3/4	39	52	66	79	92	105	118	131	144	157
27	3/4	37	49	61	73	86	98	110	122	135	147
28	3/4	34	46	57	69	80	92	103	114	126	137
29	3/4	32	43	54	64	75	86	96	107	118	129
30	3/4	30	40	50	60	70	81	91	101	111	121
31	3/4	28	38	47	57	66	76	85	95	104	114
32	3/4	27	36	45	54	63	71	80	89	98	107
33	3/4	25	34	42	51	59	68	76	84	93	101
34	3/4	24	32	40	48	56	64	72	80	88	96
35	3/4	23	30	38	45	53	61	68	76	83	91
36	3/4	22	29	36	43	50	57	65	72	79	86
37	3/4	20	27	34	41	48	55	61	68	75	82
38	3/4	20	26	33	39	46	52	59	65	72	78
39	3/4	19	25	31	37	43	50	56	62	68	74
40	3/4	18	24	30	35	41	47	53	59	65	71

For SI: 1 inch = 25.4 mm, 1 foot = 304.8 mm, 1 pound per square inch = 6.895 kPa, 1 gallon per minute = 0.963 L/s.
a. Flow rate from Section P2904.4.2.

**TABLE P2904.6.2(7)
ALLOWABLE PIPE LENGTH FOR 1-INCH CPVC PIPE**

SPRINKLER FLOW RATE ^a (gpm)	WATER DISTRIBUTION SIZE (inch)	AVAILABLE PRESSURE - P _r (psi)									
		15	20	25	30	35	40	45	50	55	60
		Allowable length of pipe from service valve to farthest sprinkler (feet)									
8	1	1049	1398	1748	2098	2447	2797	3146	3496	3845	4195
9	1	843	1125	1406	1687	1968	2249	2530	2811	3093	3374
10	1	694	925	1157	1388	1619	1851	2082	2314	2545	2776
11	1	582	776	970	1164	1358	1552	1746	1940	2133	2327
12	1	495	660	826	991	1156	1321	1486	1651	1816	1981
13	1	427	570	712	854	997	1139	1281	1424	1566	1709
14	1	372	497	621	745	869	993	1117	1241	1366	1490
15	1	328	437	546	656	765	874	983	1093	1202	1311
16	1	291	388	485	582	679	776	873	970	1067	1164
17	1	260	347	433	520	607	693	780	867	954	1040
18	1	234	312	390	468	546	624	702	780	858	936
19	1	212	282	353	423	494	565	635	706	776	847
20	1	193	257	321	385	449	513	578	642	706	770
21	1	176	235	293	352	410	469	528	586	645	704
22	1	161	215	269	323	377	430	484	538	592	646
23	1	149	198	248	297	347	396	446	496	545	595
24	1	137	183	229	275	321	366	412	458	504	550
25	1	127	170	212	255	297	340	382	425	467	510
26	1	118	158	197	237	276	316	355	395	434	474
27	1	111	147	184	221	258	295	332	368	405	442
28	1	103	138	172	207	241	275	310	344	379	413
29	1	97	129	161	194	226	258	290	323	355	387
30	1	91	121	152	182	212	242	273	303	333	364
31	1	86	114	143	171	200	228	257	285	314	342
32	1	81	108	134	161	188	215	242	269	296	323
33	1	76	102	127	152	178	203	229	254	280	305
34	1	72	96	120	144	168	192	216	240	265	289
35	1	68	91	114	137	160	182	205	228	251	273
36	1	65	87	108	130	151	173	195	216	238	260
37	1	62	82	103	123	144	165	185	206	226	247
38	1	59	78	98	117	137	157	176	196	215	235
39	1	56	75	93	112	131	149	168	187	205	224
40	1	53	71	89	107	125	142	160	178	196	214

For SI: 1 inch = 25.4 mm, 1 foot = 304.8 mm, 1 pound per square inch = 6.895 kPa, 1 gallon per minute = 0.963 L/s.
a. Flow rate from Section P2904.4.2.

TABLE P2904.6.2(8)
ALLOWABLE PIPE LENGTH FOR 3/4-INCH PEX TUBING

SPRINKLER FLOW RATE ^a (gpm)	WATER DISTRIBUTION SIZE (inch)	AVAILABLE PRESSURE - P _t (psi)									
		15	20	25	30	35	40	45	50	55	60
		Allowable length of pipe from service valve to farthest sprinkler (feet)									
8	3/4	93	123	154	185	216	247	278	309	339	370
9	3/4	74	99	124	149	174	199	223	248	273	298
10	3/4	61	82	102	123	143	163	184	204	225	245
11	3/4	51	68	86	103	120	137	154	171	188	205
12	3/4	44	58	73	87	102	117	131	146	160	175
13	3/4	38	50	63	75	88	101	113	126	138	151
14	3/4	33	44	55	66	77	88	99	110	121	132
15	3/4	29	39	48	58	68	77	87	96	106	116
16	3/4	26	34	43	51	60	68	77	86	94	103
17	3/4	23	31	38	46	54	61	69	77	84	92
18	3/4	21	28	34	41	48	55	62	69	76	83
19	3/4	19	25	31	37	44	50	56	62	69	75
20	3/4	17	23	28	34	40	45	51	57	62	68
21	3/4	16	21	26	31	36	41	47	52	57	62
22	3/4	NP	19	24	28	33	38	43	47	52	57
23	3/4	NP	17	22	26	31	35	39	44	48	52
24	3/4	NP	16	20	24	28	32	36	40	44	49
25	3/4	NP	NP	19	22	26	30	34	37	41	45
26	3/4	NP	NP	17	21	24	28	31	35	38	42
27	3/4	NP	NP	16	20	23	26	29	33	36	39
28	3/4	NP	NP	15	18	21	24	27	30	33	36
29	3/4	NP	NP	NP	17	20	23	26	28	31	34
30	3/4	NP	NP	NP	16	19	21	24	27	29	32
31	3/4	NP	NP	NP	15	18	20	23	25	28	30
32	3/4	NP	NP	NP	NP	17	19	21	24	26	28
33	3/4	NP	NP	NP	NP	16	18	20	22	25	27
34	3/4	NP	NP	NP	NP	NP	17	19	21	23	25
35	3/4	NP	NP	NP	NP	NP	16	18	20	22	24
36	3/4	NP	NP	NP	NP	NP	15	17	19	21	23
37	3/4	NP	NP	NP	NP	NP	NP	16	18	20	22
38	3/4	NP	NP	NP	NP	NP	NP	16	17	19	21
39	3/4	NP	NP	NP	NP	NP	NP	NP	16	18	20
40	3/4	NP	NP	NP	NP	NP	NP	NP	16	17	19

For SI: 1 inch = 25.4 mm, 1 foot = 304.8 mm, 1 pound per square inch = 6.895 kPa, 1 gallon per minute = 0.963 L/s.

NP - Not permitted.

a. Flow rate from Section P2904.4.2.

**TABLE P2904.6.2(9)
ALLOWABLE PIPE LENGTH FOR 1-INCH PEX TUBING**

SPRINKLER FLOW RATE ^a (gpm)	WATER DISTRIBUTION SIZE (inch)	AVAILABLE PRESSURE - P_t (psi)									
		15	20	25	30	35	40	45	50	55	60
		Allowable length of pipe from service valve to farthest sprinkler (feet)									
8	1	314	418	523	628	732	837	941	1046	1151	1255
9	1	252	336	421	505	589	673	757	841	925	1009
10	1	208	277	346	415	485	554	623	692	761	831
11	1	174	232	290	348	406	464	522	580	638	696
12	1	148	198	247	296	346	395	445	494	543	593
13	1	128	170	213	256	298	341	383	426	469	511
14	1	111	149	186	223	260	297	334	371	409	446
15	1	98	131	163	196	229	262	294	327	360	392
16	1	87	116	145	174	203	232	261	290	319	348
17	1	78	104	130	156	182	208	233	259	285	311
18	1	70	93	117	140	163	187	210	233	257	280
19	1	63	84	106	127	148	169	190	211	232	253
20	1	58	77	96	115	134	154	173	192	211	230
21	1	53	70	88	105	123	140	158	175	193	211
22	1	48	64	80	97	113	129	145	161	177	193
23	1	44	59	74	89	104	119	133	148	163	178
24	1	41	55	69	82	96	110	123	137	151	164
25	1	38	51	64	76	89	102	114	127	140	152
26	1	35	47	59	71	83	95	106	118	130	142
27	1	33	44	55	66	77	88	99	110	121	132
28	1	31	41	52	62	72	82	93	103	113	124
29	1	29	39	48	58	68	77	87	97	106	116
30	1	27	36	45	54	63	73	82	91	100	109
31	1	26	34	43	51	60	68	77	85	94	102
32	1	24	32	40	48	56	64	72	80	89	97
33	1	23	30	38	46	53	61	68	76	84	91
34	1	22	29	36	43	50	58	65	72	79	86
35	1	20	27	34	41	48	55	61	68	75	82
36	1	19	26	32	39	45	52	58	65	71	78
37	1	18	25	31	37	43	49	55	62	68	74
38	1	18	23	29	35	41	47	53	59	64	70
39	1	17	22	28	33	39	45	50	56	61	67
40	1	16	21	27	32	37	43	48	53	59	64

For SI: 1 inch = 25.4 mm, 1 foot = 304.8 mm, 1 pound per square inch = 6.895 kPa, 1 gallon per minute = 0.963 L/s.

a. Flow rate from Section P2904.4.2.

accordance with Section P2904.6.1, the size used in the hydraulic calculation.

5. The pipe length does not exceed the length permitted by Tables P2904.6.2(4) through P2904.6.2(9) or, if the piping system was hydraulically calculated in accordance with Section P2904.6.1, pipe lengths and fittings do not exceed those used in the hydraulic calculation.
6. Nonmetallic piping that conveys water to sprinklers is listed for use with fire sprinklers.
7. Piping is supported in accordance with the pipe manufacturer's and sprinkler manufacturer's installation instructions.
8. The piping system is tested in accordance with Section P2503.7.

P2904.8.2 Final inspection. The following items shall be verified upon completion of the system:

1. Sprinkler are not painted, damaged or otherwise hindered from operation.
2. Where a pump is required to provide water to the system, the pump starts automatically upon system water demand.
3. Pressure-reducing valves, water softeners, water filters or other impairments to water flow that were not part of the original design have not been installed.
4. The sign or valve tag required by Section P2904.7 is installed and the owner's manual for the system is present.

SECTION P2905 MATERIALS, JOINTS AND CONNECTIONS

P2905.1 Soil and groundwater. The installation of water service pipe, water distribution pipe, fittings, valves, appurtenances and gaskets shall be prohibited in soil and groundwater that is contaminated with solvents, fuels, organic compounds or other detrimental materials that cause permeation, corrosion, degradation or structural failure of the water service or water distribution piping material.

P2905.1.1 Investigation required. Where detrimental conditions are suspected by or brought to the attention of the *building official*, a chemical analysis of the soil and groundwater conditions shall be required to ascertain the acceptability of the water service material for the specific installation.

P2905.1.2 Detrimental condition. When a detrimental condition exists, *approved* alternate materials or alternate routing shall be required.

P2905.2 Lead content. Pipe and fittings used in the water-supply system shall have a maximum of 8 percent lead.

P2905.3 Polyethylene plastic piping installation. Polyethylene pipe shall be cut square using a cutter designed for plastic pipe. Except where joined by heat fusion, pipe ends shall be chamfered to remove sharp edges. Pipe that has been kinked

shall not be installed. For bends, the installed radius of pipe curvature shall be greater than 30 pipe diameters or the coil radius when bending with the coil. Coiled pipe shall not be bent beyond straight. Bends shall not be permitted within 10 pipe diameters of any fitting or valve. Joints between polyethylene plastic pipe and fittings shall comply with Sections P2905.3.1 and P2905.3.2.

P2905.3.1 Heat-fusion joints. Joint surfaces shall be clean and free from moisture. Joint surfaces shall be heated to melting temperature and joined. The joint shall be undisturbed until cool. Joints shall be made in accordance with ASTM D 2657.

P2905.3.2 Mechanical joints. Mechanical joints shall be installed in accordance with the manufacturer's installation instructions.

P2905.4 Water service pipe. Water service pipe shall conform to NSF 61 and shall conform to one of the standards listed in Table P2905.4. Water service pipe or tubing, installed underground and outside of the structure, shall have a minimum working pressure rating of 160 pounds per square inch at 73°F (1103 kPa at 23°C). Where the water pressure exceeds 160 pounds per square inch (1103 kPa), piping material shall have a rated working pressure equal to or greater than the highest available pressure. Water service piping materials not third-party certified for water distribution shall terminate at or before the full open valve located at the entrance to the structure. Ductile iron water service piping shall be cement mortar lined in accordance with AWWA C104.

P2905.4.1 Dual check-valve-type backflow preventer. Where a dual check-valve backflow preventer is installed on the water supply system, it shall comply with ASSE 1024 or CSA B64.6.

P2905.4.2 Water service installation. Trenching, pipe installation and backfilling shall be in accordance with Section P2604. Water-service pipe is permitted to be located in the same trench with a *building sewer* provided such sewer is constructed of materials listed for underground use within a building in Section P3002.1. If the *building sewer* is not constructed of materials listed in Section P3002.1, the water-service pipe shall be separated from the *building sewer* by a minimum of 5 feet (1524 mm), measured horizontally, of undisturbed or compacted earth or placed on a solid ledge at least 12 inches (305 mm) above and to one side of the highest point in the sewer line.

Exception: The required separation distance shall not apply where a water service pipe crosses a sewer pipe, provided that the water service pipe is sleeved to at least 5 feet (1524 mm), horizontally from the sewer pipe centerline, on both sides of the crossing with pipe materials listed in Tables P2905.4, P3002.1(1), P3002.1(2) or P3002.2.

P2905.5 Water-distribution pipe. Water-distribution piping within *dwelling units* shall conform to NSF 61 and shall conform to one of the standards listed in Table P2905.5. All

hot-water-distribution pipe and tubing shall have a minimum pressure rating of 100 psi at 180°F (689 kPa at 82°C).

P2905.6 Fittings. Pipe fittings shall be *approved* for installation with the piping material installed and shall comply with the applicable standards listed in Table P2905.6. All pipe fittings used in water supply systems shall also comply with NSF 61.

P2905.7 Flexible water connectors. Flexible water connectors, exposed to continuous pressure, shall conform to ASME A112.18.6. Access shall be provided to all flexible water connectors.

P2905.8 Joint and connection tightness. Joints and connections in the plumbing system shall be gas tight and water tight for the intended use or required test pressure.

P2905.9 Plastic pipe joints. Joints in plastic piping shall be made with *approved* fittings by solvent cementing, heat fusion, corrosion-resistant metal clamps with insert fittings or compression connections. Flared joints for polyethylene pipe are permitted in accordance with Section P2905.3.

P2905.9.1 Solvent cementing. Solvent-cemented joints shall comply with Sections P2905.9.1.1 through P2905.9.1.3.

P2905.9.1.1 ABS plastic pipe. Solvent cement for ABS plastic pipe conforming to ASTM D 2235 shall be applied to all joint surfaces.

P2905.9.1.2 CPVC plastic pipe. Joint surfaces shall be clean and free from moisture and an *approved* primer shall be applied. Solvent cement for CPVC plastic pipe, orange in color and conforming to ASTM F 493, shall be applied to all joint surfaces. The parts shall be joined while the cement is wet and in accordance with ASTM D 2846 or ASTM F 493. Solvent-cement joints shall be permitted above or below ground.

Exception: A primer is not required where all of the following conditions apply:

1. The solvent cement used is third-party certified as conforming to ASTM F 493.
2. The solvent cement used is yellow in color.
3. The solvent cement is used only for joining 1/2-inch (13 mm) through 2-inch (51 mm) diameter CPVC pipe and fittings.
4. The CPVC pipe and fittings are manufactured in accordance with ASTM D 2846.

P2905.9.1.3 PVC plastic pipe. A purple primer that conforms to ASTM F 656 shall be applied to PVC sol-

TABLE P2905.4
WATER SERVICE PIPE

MATERIAL	STANDARD
Acrylonitrile butadiene styrene (ABS) plastic pipe	ASTM D 1527; ASTM D 2282
Asbestos-cement pipe	ASTM C 296
Brass pipe	ASTM B 43
Chlorinated polyvinyl chloride (CPVC) plastic pipe	ASTM D 2846; ASTM F 441; ASTM F 442; CSA B137.6
Copper or copper-alloy pipe	ASTM B 42; ASTM B 302
Copper or copper-alloy tubing (Type K, WK, L, WL, M or WM)	ASTM B 75; ASTM B 88; ASTM B 251; ASTM B 447
Cross-linked polyethylene/aluminum/cross-linked polyethylene (PEX-AL-PEX) pipe	ASTM F 1281; ASTM F 2262; CSA B137.10M
Cross-linked polyethylene/aluminum/high-density polyethylene (PEX-AL-HDPE)	ASTM F 1986
Cross-linked polyethylene (PEX) plastic tubing	ASTM F 876; ASTM F 877; CSA B137.5
Ductile iron water pipe	AWWA C151; AWWA C115
Galvanized steel pipe	ASTM A 53
Polyethylene/aluminum/polyethylene (PE-AL-PE) pipe	ASTM F 1282; CSA CAN/CSA-B137.9M
Polyethylene (PE) plastic pipe	ASTM D 2104; ASTM D 2239; CSA-B137.1
Polyethylene (PE) plastic tubing	ASTM D 2737; CSA B137.1
Polypropylene (PP) plastic pipe or tubing	ASTM F 2389; CSA B137.11
Polyvinyl chloride (PVC) plastic pipe	ASTM D 1785; ASTM D 2241; ASTM D 2672; CSA B137.3
Stainless steel (Type 304/304L) pipe	ASTM A 312; ASTM A 778
Stainless steel (Type 316/316L) pipe	ASTM A 312; ASTM A 778

**TABLE P2905.5
WATER DISTRIBUTION PIPE**

MATERIAL	STANDARD
Brass pipe	ASTM B 43
Chlorinated polyvinyl chloride (CPVC) plastic pipe and tubing	ASTM D 2846; ASTM F 441; ASTM F 442; CSA B137.6
Copper or copper-alloy pipe	ASTM B 42; ASTM B 302
Copper or copper-alloy tubing (Type K, WK, L, WL, M or WM)	ASTM B 75; ASTM B 88; ASTM B 251; ASTM B 447
Cross-linked polyethylene (PEX) plastic tubing	ASTM F 876; ASTM F 877; CSA B137.5
Cross-linked polyethylene/aluminum/cross-linked polyethylene (PEX-AL-PEX) pipe	ASTM F 1281; ASTM F 2262; CSA B137.10M
Cross-linked polyethylene/aluminum/high-density polyethylene (PEX-AL-HDPE)	ASTM F 1986
Galvanized steel pipe	ASTM A 53
Polyethylene/aluminum/polyethylene (PE-AL-PE) composite pipe	ASTM F 1282
Polypropylene (PP) plastic pipe or tubing	ASTM F 2389; CSA B137.11
Stainless steel (Type 304/304L) pipe	ASTM A 312; ASTM A 778

**TABLE P2905.6
PIPE FITTINGS**

MATERIAL	STANDARD
Acrylonitrile butadiene styrene (ABS) plastic	ASTM D 2468
Brass	ASTM F1974
Cast-iron	ASME B16.4; ASME B16.12
Chlorinated polyvinyl chloride (CPVC) plastic	ASSE 1061; ASTM D 2846; ASTM F 437; ASTM F 438; ASTM F 439; CSA B137.6
Copper or copper alloy	ASSE 1061; ASME B16.15; ASME B16.18; ASME B16.22; ASME B16.23; ASME B16.26; ASME B16.29
Cross-linked polyethylene/aluminum/high-density polyethylene (PEX-AL-HDPE)	ASTM F 1986
Fittings for cross-linked polyethylene (PEX) plastic tubing	ASSE 1061; ASTM F 877; ASTM F 1807; ASTM F 1960; ASTM F 2080; ASTM F 2098; ASTM F 2159; ASTM F 2434; CSA B137.5
Gray iron and ductile iron	AWWA C110; AWWA C153
Malleable iron	ASME B16.3
Insert fittings for Polyethylene/aluminum/polyethylene (PE-AL-PE) and cross-linked polyethylene/aluminum/polyethylene (PEX-AL-PEX)	ASTM F 1974; ASTM F 1281; ASTM F 1282; CSA B137.9; CSA B137.10
Polyethylene (PE) plastic	ASTM D 2609; CSA B137.1
Polypropylene (PP) plastic pipe or tubing	ASTM F 2389; CSA B137.11
Polyvinyl chloride (PVC) plastic	ASTM D 2464; ASTM D 2466; ASTM D 2467; CSA B137.2; CSA B137.3
Stainless steel (Type 304/304L) pipe	ASTM A 312; ASTM A 778
Stainless steel (Type 316/316L) pipe	ASTM A 312; ASTM A 778
Steel	ASME B16.9; ASME B16.11; ASME B16.28

vent cemented joints. Solvent cement for PVC plastic pipe conforming to ASTM D 2564 shall be applied to all joint surfaces.

P2905.9.1.4 Cross-linked polyethylene plastic (PEX). Joints between cross-linked polyethylene plastic tubing or fittings shall comply with Section P2905.9.1.4.1 or Section P2905.9.1.4.2.

P2905.9.1.4.1 Flared joints. Flared pipe ends shall be made by a tool designed for that operation.

P2905.9.1.4.2 Mechanical joints. Mechanical joints shall be installed in accordance with the manufacturer's instructions. Fittings for cross-linked polyethylene (PEX) plastic tubing shall comply with the applicable standards listed in Table P2905.6 and shall be installed in accordance with the manufacturer's installation instructions. PEX tubing shall be factory marked with the applicable standards for the fittings that the PEX manufacturer specifies for use with the tubing.

P2905.10 Polypropylene (PP) plastic. Joints between PP plastic pipe and fittings shall comply with Section P2905.10.1 or P2905.10.2.

P2905.10.1 Heat-fusion joints. Heat fusion joints for polypropylene pipe and tubing joints shall be installed with socket-type heat-fused polypropylene fittings, butt-fusion polypropylene fittings or electrofusion polypropylene fittings. Joint surfaces shall be clean and free from moisture. The joint shall be undisturbed until cool. Joints shall be made in accordance with ASTM F 2389.

P2905.10.2 Mechanical and compression sleeve joints. Mechanical and compression sleeve joints shall be installed in accordance with the manufacturer's installation instructions.

P2905.11 Cross-linked polyethylene/aluminum/cross-linked polyethylene. Joints between polyethylene/aluminum/polyethylene (PE-AL-PE) and cross-linked polyethylene/aluminum/cross-linked polyethylene (PEX-AL-PEX) pipe and fittings shall comply with Section P2905.11.1.

P2905.11.1 Mechanical joints. Mechanical joints shall be installed in accordance with the manufacturer's instructions. Fittings for PE-AL-PE and PEX-AL-PEX as described in ASTM F 1974, ASTM F 1281, ASTM F 1282, CSA B137.9 and CSA B137.10 shall be installed in accordance with the manufacturer's instructions.

P2905.12 Stainless steel. Joints between stainless steel pipe and fittings shall comply with Sections P2905.12.1 and P2905.12.2.

P2905.12.1 Mechanical joints. Mechanical joints shall be installed in accordance with the manufacturer's instructions.

P2905.12.2 Welded joints. Joint surfaces shall be cleaned. The joint shall be welded autogenously or with an *approved* filler metal in accordance with ASTM A 312.

P2905.13 Threaded pipe joints. Threaded joints shall conform to American National Taper Pipe Thread specifications. Pipe ends shall be deburred and chips removed. Pipe joint compound shall be used only on male threads.

P2905.14 Soldered joints. Soldered joints in tubing shall be made with fittings *approved* for water piping and shall conform to ASTM B 828. Surfaces to be soldered shall be cleaned bright. The joints shall be properly fluxed and made with *approved* solder. Solders and fluxes used in potable water-supply systems shall have a maximum of 0.2 percent lead. Fluxes shall conform to ASTM B 813.

P2905.15 Flared joints. Flared joints in water tubing shall be made with *approved* fittings. The tubing shall be reamed and then expanded with a flaring tool.

P2905.16 Above-ground joints. Joints within the building between copper pipe or CPVC tubing, in any combination with compatible outside diameters, are permitted to be made with the use of *approved* push-in mechanical fittings of a pressure-lock design.

P2905.17 Joints between different materials. Joints between different piping materials shall be made in accordance with Sections P2905.17.1, P2905.17.2 and P2905.17.3 or with a mechanical joint of the compression or mechanical sealing type having an elastomeric seal conforming to ASTM D 1869 or ASTM F 477. Joints shall be installed in accordance with the manufacturer's instructions.

P2905.17.1 Copper or copper-alloy tubing to galvanized steel pipe. Joints between copper or copper-alloy tubing and galvanized steel pipe shall be made with a brass fitting or dielectric fitting. The copper tubing shall be joined to the fitting in an *approved* manner, and the fitting shall be screwed to the threaded pipe.

P2904.17.2 Plastic pipe or tubing to other piping material. Joints between different types of plastic pipe or between plastic pipe and other piping material shall be made with an approved adapter fitting.

P2905.17.3 Stainless steel. Joints between stainless steel and different piping materials shall be made with a mechanical joint of the compression or mechanical-sealing type or a dielectric fitting.

P2905.18 Press joints. Press-type mechanical joints in copper tubing shall be made in accordance with the manufacturer's instructions using *approved* tools which affix the copper fitting with integral O-ring to the tubing.

SECTION P2906 CHANGES IN DIRECTION

P2906.1 Bends. Changes in direction in copper tubing are permitted to be made with bends having a radius of not less than four diameters of the tube, providing such bends are made by use of forming equipment that does not deform or create loss in cross-sectional area of the tube.

SECTION P2907 SUPPORT

P2907.1 General. Pipe and tubing support shall conform to Section P2605.

SECTION P2908
DRINKING WATER TREATMENT UNITS

P2908.1 Design. Drinking water treatment units shall meet the requirements of NSF 42, NSF 44 or NSF 53.

P2908.2 Reverse osmosis drinking water treatment units. Point-of-use reverse osmosis drinking water treatment units, designed for residential use, shall meet the requirements of NSF 58. Waste or discharge from reverse osmosis drinking water treatment units shall enter the drainage system through an air gap or an air gap device that meets the requirements of NSF 58.

P2908.3 Connection tubing. The tubing to and from drinking water treatment units shall be of a size and material as recommended by the manufacturer. The tubing shall comply with NSF 14, NSF 42, NSF 44, NSF 53, NSF 58 or NSF 61.

